

RESEARCH PAPER

A carbon monoxide 'single breath' method to measure total haemoglobin mass: a feasibility study

Lisa-Marie Krehl¹  | James O. M. Plumb²  | Nadine B. Wachsmuth¹  |
 Sandra Haupt¹ | Shriya B. Kumar³ | James M. Otto² | Janis Schierbauer¹ |
 Michael P. W. Grocott²  | Hugh E. Montgomery⁴  | Walter F. J. Schmidt¹ 

¹ Department of Sports Medicine/Sports Physiology, University of Bayreuth, Bayreuth 95440, Germany

² Respiratory and Critical Care Research Area, NIHR Biomedical Research Centre, University Hospital Southampton NHS Foundation Trust/University of Southampton, Southampton, UK

³ Centre for Human Integrative Physiology, Faculty of Medicine, University of Southampton, Southampton, UK

⁴ Centre for Human Health and Performance/Institute of Sport, Exercise and Health, University College London, and NIHR University College London Hospitals Biomedical Research Centre, London, UK

Correspondence

Walter Schmidt, Department of Sports Medicine/Sports Physiology, University of Bayreuth, 95440 Bayreuth, Universitaetsstrasse 30, Germany.
 Email: walter.schmidt@uni-bayreuth.de

H. E. Montgomery and Walter F. J. Schmidt are joint senior authors

L.-M. Krehl and J. O. M. Plumb are joint first authors

Funding information

This study was financially supported by regular funds of the University of Bayreuth.

[Correction added on 13 January 2021, after first online publication: Projekt DEAL funding statement has been added.]

Edited by: Andrew Sheel

Abstract

Anaemia is defined by the concentration of haemoglobin (Hb). However, this value is dependent upon both the total circulating haemoglobin mass (tHb-mass) and the plasma volume (PV) – neither of which is routinely measured. Carbon monoxide (CO)-rebreathing methods have been successfully used to determine both PV and tHb-mass in various populations. However, these methods are not yet suitable for ventilated patients. This study aimed to modify the CO-rebreathing procedure such that a single inhalation of a CO bolus would enable its use in ventilated patients. Eleven healthy volunteers performed four CO-rebreathing tests in a randomized order, inhaling an identical CO volume. In two tests, CO was rebreathed for 2 min (optimized CO rebreathing; oCOR), and in the other two tests, a single inhalation of a CO bolus was conducted with a subsequent breath hold of 15 s (Proc_{new}15s) or 30 s (Proc_{new}30s). Subsequently, the CO volume in the exhaled air was continuously determined for 20 min. The amount of CO exhaled after 7 and 20 min was respectively 3.1 ± 0.3 and 5.9 ± 1.1 ml for oCOR, 8.7 ± 3.6 and 12.0 ± 4.4 ml for Proc_{new}15s and 5.1 ± 2.0 and 8.4 ± 2.6 ml for Proc_{new}30s. tHb-mass was 843 ± 293 g determined by oCOR, 821 ± 288 g determined by Proc_{new}15s (difference: $P < 0.05$) and 849 ± 311 g determined by Proc_{new}30s. Bland–Altman plots demonstrated slightly lower tHb-mass values for Proc_{new}15s compared with oCOR (-21.8 ± 15.3 g) and similar values for Proc_{new}30s. In healthy volunteers, a single inhalation of a CO bolus, preferably followed by a 30 s breath hold, can be used to determine tHb-mass. These results must now be validated for ventilated patients.

KEYWORDS

blood volume, carboxy-haemoglobin, CO rebreathing, ventilated patients

This is an open access article under the terms of the [Creative Commons Attribution](https://creativecommons.org/licenses/by/4.0/) License, which permits use, distribution and reproduction in any medium, provided the original work is properly cited.

© 2020 The Authors. *Experimental Physiology* published by John Wiley & Sons Ltd on behalf of The Physiological Society

1 | INTRODUCTION

Haemoglobin (Hb) is the oxygen-carrying pigment of the circulation. Its circulating concentration ([Hb]) is routinely measured in clinical practice, and low values are used to define 'anaemia' (Beutler & Waalen, 2006). However, [Hb] is determined by the total circulating mass of Hb (tHb-mass) and the volume of plasma (PV) in which it is carried. The measurement of such independent variables has distinct advantages given that PV can change substantially with disease. The importance of tHb-mass measurement in the clinical setting and the advantages over [Hb] have been discussed previously (Otto et al., 2017a,b; Plumb et al., 2016). Indeed, [Hb] correlates poorly with tHb-mass in patients with chronic liver disease or heart failure, in whom PV may be expanded (Otto et al., 2017a). Despite this fact, [Hb] is the major trigger for the transfusion of red blood cells.

Likewise, perioperative changes in tHb-mass and PV are common (Iijima et al., 2013; Makaryus et al., 2018) due to blood loss, administration of red blood cells or haemodilution through administration of intravenous fluids or through salt/water retention due to the 'surgical stress response' (Rassam & Counsell, 2005). Fluid distribution between physiological compartments and the impact of hypo/hypervolaemia on the glycocalyx and therefore the functional integrity of the intravascular space also influence PV (Strunden et al., 2011). However, the decision to transfuse blood to a patient in clinical practice in general, and perioperative and critical care settings in particular, hinges on a variety of factors. There is a growing recognition that [Hb] may not be the best clinical indicator to guide such decisions (Plumb et al., 2016; Shander & Ferraris, 2017).

tHb-mass and derived PV can be determined by different dilution methods, in which carbon monoxide (CO) has been found to be the easiest and most precise marker to use (Gore et al., 2005). Using the inhalation of a known volume of CO (thus labelling Hb as carboxyhaemoglobin, COHb) allows the measurement of tHb-mass and, thus, the calculation of PV. In self-ventilating subjects, this is achieved using the so-called 'optimized CO rebreathing method' (oCOR). However, this protocol relies upon the participant being alert, able to follow instructions, and able to control their breathing through a closed circuit, which in turn precludes the use of oCOR in participants who are receiving mandatory ventilation from a mechanical ventilator, either under anaesthesia or when sedated in the intensive care unit. We hypothesized that delivery of a single CO bolus into the breathing circuit of a participant without the need for rebreathing could be used to reliably measure tHb-mass, so long as exhaled gas could be analysed. We thus sought to develop such a technique. Here, we describe this development and early data relating to its likely reliability. The primary aim of this study was to develop a new method for measuring tHb-mass in healthy participants simulating a procedure that might be used in participants on a mechanical ventilator (Proc_{new}) and to evaluate the feasibility of this novel method. We aimed to assess reliability compared to the standard oCOR method. We also repeated the oCOR test to quantify the reliability of the standard method within this experiment.

New Findings

- **What is the central question of this study?**

Is it possible to modify the CO-rebreathing method to acquire reliable measurements of haemoglobin mass in ventilated patients?

- **What is the main finding and its importance?**

A 'single breath' of CO with a subsequent 30 s breath hold provides almost as exact a measure of haemoglobin mass as the established optimized CO-rebreathing method when applied to healthy subjects. The modified method has now to be checked in ventilated patients before it can be used to quantify the contributions of blood loss and of dilution to the severity of anaemia.

2 | METHODS

2.1 | Ethical approval

Ethical approval was granted by the South-Central Hampshire B Research Ethics Committee (REC reference: 15/SC/0496) and from the ethics committee of the University of Bayreuth (reference: O1305/1-GB). The study conformed to the standards set by the *Declaration of Helsinki*, except for registration in a database. Written informed consent was obtained from all participants. The subjects volunteered to participate in the study and were free to withdraw at any time without needing to provide a reason.

2.2 | Subjects

This feasibility study took place at the University Hospital Southampton NHS Foundation Trust, UK, and at the University of Bayreuth, Germany. Eleven healthy non-smoking test subjects (five women, six men) with moderate physical training status took part in the study (for anthropometric data of these subjects see Table 1).

2.3 | Study design

In preliminary tests, we checked whether a single inhalation of a CO bolus could achieve an increase in COHb concentration ([COHb]) that would be sufficient to determine tHb-mass. For this purpose, tHb-mass was measured twice; results from the established CO-rebreathing method (Schmidt & Prommer, 2005), that is, 2 min CO inhalation within a closed spirometry system, were compared to those from a single inhalation with subsequent 10 s breath holding and 15 min collection of expired air. Because the difference in tHb-mass was lower than 50 g

TABLE 1 Anthropometric and haematological characteristics of the test subjects

	Females	Males
<i>n</i>	5	6
Age (years)	33.2 ± 11.6	26.8 ± 4.0
Height (cm)	165.5 ± 8.4	187.2 ± 9.8
Body mass (kg)	59.2 ± 7.0	85.9 ± 10.9
BMI (kg/m ²)	21.6 ± 1.1	24.4 ± 1.4
LBM (kg)	45.3 ± 6.9	72.2 ± 10.5
[Hb] _{cap} (g/dl)	13.9 ± 0.7	15.9 ± 1.1
Hkt _{cap} (%)	41.8 ± 1.2	46.1 ± 3.0

[Hb]_{cap} haemoglobin concentration determined in capillary blood, Hkt_{cap} haematocrit determined in capillary blood.

in only six of 13 comparisons, breath holding was prolonged to 15 and 30 s and collection of the expired air to 20 min in the main study.

In the main study, at least four CO-rebreathing tests were carried out by 11 subjects in a randomized order. Two of the tests consisted of the established CO-rebreathing method over 2 min (oCOR). In the third and fourth tests, the subjects inhaled a CO bolus followed by a breath hold for 15 s (Proc_{new}15s) or 30 s (Proc_{new}30s). Afterwards, the volume and CO concentration of the expiratory air were continuously analysed for 20 min, and the whole amount of exhaled air was finally collected in a Douglas bag. tHb-mass was calculated at 2 min intervals using the prevailing [COHb] and the accumulated CO volume in the expired air. Additionally, at the end of the test, tHb-mass was obtained by using the total expiratory volume and the average [COHb] in the Douglas bag. To evaluate possible influences of the test arrangement, that is, collection and analysis of the expired air after inhaling the CO bolus, CO exhalation was determined from six subjects in a fifth test approach using the same methodology as described above after a conventional 2 min CO-rebreathing procedure (oCOR_{+20min}).

2.4 | Established carbon monoxide rebreathing method

tHb-mass was determined using the optimized CO-rebreathing (oCOR) method as described and modified by Schmidt and Prommer (Prommer & Schmidt, 2007; Schmidt & Prommer, 2005). Briefly, a bolus of 99.97% CO (0.8–1.0 ml CO/kg body mass, depending on the training status) was administered to subjects and rebreathed along with 3 litres of 100% O₂ for 2 min. Three arterialized capillary blood samples were taken from a hyperaemic earlobe (Finalgon, Sanofi-Aventis, Frankfurt, Germany) before the rebreathing procedure, and at minutes 6 and 8 after the rebreathing procedure, and each sample was analysed in triplicate using an OSM3 haemoximeter (Radiometer, Brønshøj, Denmark). End-tidal [CO] was assessed before and 2 min after the rebreathing procedure using a portable CO detector (Draeger Pac7000, Lübeck, Germany). tHb-mass was assessed in duplicate (test 1 and test 2) using this method, and the mean of both tests was used for comparison with the results of the modified procedures. The typical

error for tHb-mass measurements determined from these duplicate tests was 1.0%.

2.5 | Modified method

To adapt the method so that it can be used in everyday clinical practice, several modifications were necessary (see Figure 1). Since a patient frequently cannot put the spirometer into their mouth by themselves, the gas supply was replaced by a mask (Hans Rudolph, Inc., Shawnee, KS, USA) with an access port for the CO supply. This access port is designed in such a way that the manually administered CO from a syringe passes the mask via a small tube directly into the back of the mouth and thus into the test person's inhalation path. In contrast to the established method, in which rebreathing occurs in a closed system, this modification presents an open system in which ambient air is inhaled via a three-way valve. The inhaled and expired air passes a volume flow sensor (breath-by-breath registration, Metalyzer 3B, Cortex Biophysics GmbH, Leipzig, Germany) and subsequently a small mixing chamber, which is equipped with a CO sensor (Draeger Pak 7000, Liebfeld, Switzerland), and is finally collected in a Douglas bag (Cranlea Human Performance Ltd, Birmingham, UK).

After connecting and accustoming the subject to the equipment for at least 10 min in the sitting position, the subject exhaled normally, and the three-way valve was turned. Subsequently, the subject deeply inhaled, and CO was administered by the investigator via the access port into the subject's inhalation path. The subject held their breath for 15 s (test 3, Proc_{new}15s) or 30 s (test 4, Proc_{new}30s) and breathed normally thereafter for the following 20 min into the Douglas bag.

Until the fifth minute after starting the test, the CO concentration and the volume of the exhaled air were monitored at 30 s intervals and thereafter at 1 min intervals until disconnecting the subject from the equipment after 20 min. In the same way as in test 1 and test 2, three capillary blood samples were taken before the test, one sample each was collected after 1 and 2 min, and then further samples were taken every 2 min until min 20.

2.6 | tHb-mass calculation

For the established method (tests 1 and 2), tHb-mass was calculated as described previously (Schmidt & Prommer, 2005):

$$\text{tHb} - \text{mass (g)} = K \times \text{MCO} \times 100 / (\Delta\text{COHb}\% \times 1.39) \quad (1)$$

where $K = (\text{current barometric pressure}/760) \times [1 + (0.003661 \times \text{current temperature})]$,

$$\begin{aligned} \text{MCO} &= \text{CO}_{\text{adm}} - (\text{CO}_{\text{system+lung(AfterDisconnection)}} + \\ &\quad \text{CO}_{\text{exhaled(AfterDisconnection)}}) - M_{\text{Hb}} \text{CO}_{\text{adm}} \\ &= \text{CO volume administered into the system} \\ &\quad - \text{CO}_{\text{system+lung(AfterDisconnection)}} \\ &= \text{CO concentration in the spirometer} \times (\text{spirometer volume} + \\ &\quad \text{lung residual volume}) \end{aligned}$$

$$\begin{aligned} M_{\text{Hb}} &= \text{CO diffusing to myoglobin} \\ &= \Delta \text{end-tidal CO concentration} \times \text{alveolar ventilation} \times \text{time} \end{aligned}$$

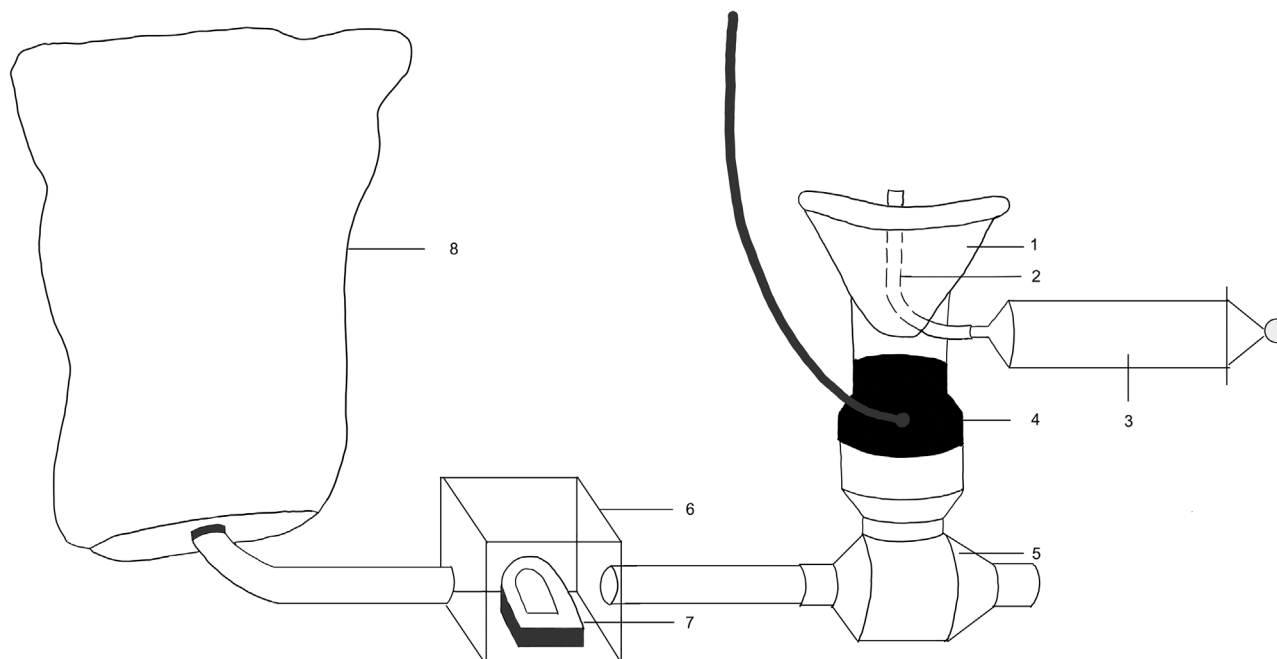

FIGURE 1 Experimental set-up and equipment for the single-breath method. 1: breathing mask; 2: tube inserted into the subject's inhalation path; 3: syringe for CO administration; 4: flow meter; 5: 3-way valve; 6: mixing chamber; 7: CO sensor; 8: Douglas bag

$\Delta\text{COHb}\%$ is the difference between basal $\text{COHb}\%$ and $\text{COHb}\%$ in the blood samples after CO administration. $1.39 = \text{Hüfners number (ml CO} \times \text{g Hb}^{-1})$ (e.g. Gorelov, 2004).

For tests 3 and 4 ($\text{Proc}_{\text{new}15\text{s}}$ and $\text{Proc}_{\text{new}30\text{s}}$), tHb-mass was calculated using formula (1) in two modified ways: (i) for each time point of taking blood after CO inhalation using the corresponding COHb concentrations and accumulated values for CO exhalation ($\text{MCO} = \text{CO}_{\text{adm}} - \text{CO}_{\text{exhaled}} - \text{M}_{\text{Hb}}$), and (ii) using the COHb concentration at min 20 and the totally exhaled CO volume collected in the Douglas bag. To compare the results of the new methods with those of oCOR, tHb-mass was calculated for min 7 ($\text{tHb-mass}_{\text{min}7}$) as well as using data from the whole test, that is, the mean from the plateau between min 6 and 20 ($\text{tHb-mass}_{\text{plateau}}$) and for min 20 using the data from the air collected in the Douglas bag ($\text{tHb-mass}_{\text{DouglasBag}}$).

2.7 | Statistical analysis

Statistical analysis was performed using IBM SPSS Statistics (version 25 for Windows, IBM Corp., Armonk, NY, USA). Values are presented as the mean \pm standard deviation (SD), unless otherwise stated. Categorical variables are presented as frequencies (%).

This was a feasibility study, and a formal power calculation was therefore not required. Test-retest data (repeated measures from the same patient with different analytical methods) are presented using Bland-Altman plots with limits of agreement (Bland & Altman, 1986). Additionally, a specific approach to compute reliability statistics to compare test-retest performance expressed as the typical error of measurement (TE) was used (see Hopkins, 2000).

Student's paired *t*-test was used to compare mean values from both tests at identical time points, and a paired *t*-test was also used to compare the mean values at different time points of the identical test. All tests were two-sided, and statistical significance was set at $P < 0.05$. To minimize the risk for type I errors, a correction for multiple measurements according to Benjamini & Hochberg (1995) was performed.

3 | RESULTS

All of the tests were conducted without complications or adverse events. All participants inhaled the identical CO volume during the four tests (63.3 ± 23.1 ml; males 82.1 ± 16.8 ml, females 44.5 ± 6.3 ml). The exhaled CO volume was highest in the first minute of $\text{Proc}_{\text{new}15\text{s}}$ (6.3 ± 3.5 ml; $\text{Proc}_{\text{new}30\text{s}}$ 2.9 ± 1.6 ml). This initial phase was followed by an almost linear and parallel increase in both new procedures, showing an accumulation of 8.7 ± 3.6 and 5.1 ± 2.0 ml in min 7 and 12.0 ± 4.4 and 8.4 ± 2.6 ml in min 20, respectively. When the expired air was collected after $\text{oCOR}_{+20\text{min}}$, the values (3.1 ± 0.3 and 5.9 ± 1.1 ml) were clearly below those of $\text{Proc}_{\text{new}15\text{s}}$ and $\text{Proc}_{\text{new}30\text{s}}$ (Figure 2) and not different from the volume exhaled 7 min after oCOR.

[COHb] exhibited well-known time-dependent changes, with a fast increase in the first minute followed by a rapid and then decelerating decrease during the rest of the observation period (Figure 3). The values of the new procedures were clearly below those of $\text{oCOR}_{+20\text{min}}$. In min 7, the CO volume ligated to Hb was 59.5 ± 22.5 ml (oCOR), 57.2 ± 21.5 ml ($\text{Proc}_{\text{new}30\text{s}}$) and 53.9 ± 21.6 ml ($\text{Proc}_{\text{new}15\text{s}}$),

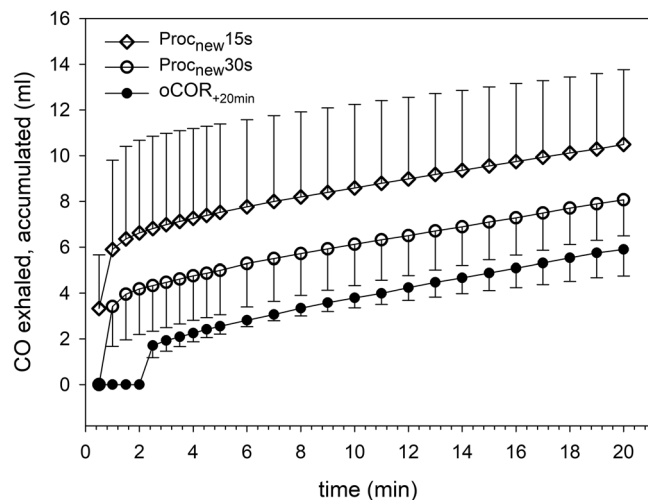

FIGURE 2 Cumulative CO volume exhaled after the three different methods of CO application. $n = 6$; Proc_{new}15s: single CO bolus inhalation with 15 s breath holding; Proc_{new}30s: single CO bolus inhalation with 30 s breath holding; oCOR_{+20min}: 2 min CO rebreathing followed by an 18 min analysis of exhaled air

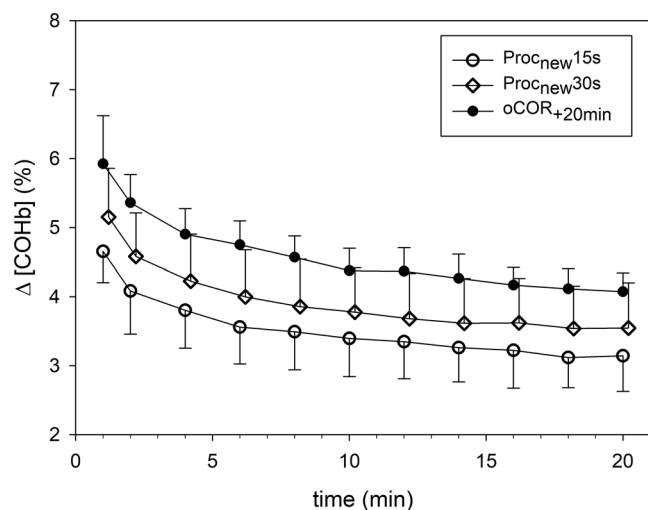

FIGURE 3 Changes in carboxy-haemoglobin ([COHb]) concentration after the inhalation of CO by three different application methods. $n = 6$; Proc_{new}15s: single CO bolus inhalation with 15 s breath holding; Proc_{new}30s: single CO bolus inhalation with 30 s breath holding; oCOR_{+20min}: 2 min CO rebreathing followed by an 18 min analysis of exhaled air

corresponding to $94.0 \pm 2.1\%$, $90.4 \pm 4.7\%$ and $85.2 \pm 6.0\%$ of the inhaled CO volume, respectively.

tHb-mass was calculated for min 1 and 2 and then further measured in 2 min steps until min 20. We found increasing tHb-mass values for Proc_{new}15s until min 6 (Figure 4a) and for Proc_{new}30s until min 8 (Figure 4b) followed by a plateau after both procedures until min 20. Comparing the tHb-mass determined at min 7 yielded similar results for the three methods (Table 2). When tHb-mass from oCOR was compared with tHb-mass_{plateau} and tHb-mass_{DouglasBag}, we found slightly lower values for Proc_{new}15s and very similar values for

Proc_{new}30s (Table 2). Comparison of tHb-mass values obtained with the established method (oCOR) and with oCOR_{+20min}, that is, with collection of the expired air as in Proc_{new}s, yielded almost identical results (Table 2).

Bland-Altman plots comparing oCOR and the new procedures demonstrate slightly lower tHb-mass values for Proc_{new}15s (tHb-mass_{plateau}: -21.8 ± 15.3 g; tHb-mass_{DouglasBag}: -12.2 ± 24.2 g) and very similar values for Proc_{new}30s over a large range of tHb-mass values between 450 and 1300 g (Figure 5).

4 | DISCUSSION

We wished to identify a way to measure tHb-mass in mechanically ventilated patients. We thus explored whether it is possible to reliably measure tHb-mass using a single-breath inhalation (with a 15 or 30 s breath hold) of CO gas and showed for the first time that it is feasible (Proc_{new}). Exhaled gas was collected and measured for the duration of the testing period (20 min). Our data suggest that Proc_{new} with 15 and 30 s breath holds was closely related to the established CO-rebreathing method.

The principle of the CO-rebreathing method is to administer a defined amount of CO by breathing to determine the resulting COHb concentration in the completely mixed blood and to take into account the CO not bound to the Hb, that is CO exhaled and CO diffused to myoglobin. When these conditions are fulfilled, different procedures of the CO method can be applied.

Modifications to the CO rebreathing technique for the measurement of tHb-mass have therefore been made many times since the technique was revived by Fogh-Andersen et al. (1990), notably in 1995 when Burge and Skinner achieved improved precision of the measurement (Burge & Skinner, 1995). The current technique described by Schmidt and Prommer reduced the rebreathing period to only 2 min to improve convenience for participants (Otto et al., 2017a,b; Plumb et al., 2020; Schmidt & Prommer, 2005). The finding that a bolus of CO gas inhaled with a single breath and only rebreathed for 2 min led to valid and reliable results characterized by a typical error between 1% and 2% allowed the method to be used in a variety of different settings. Initially, these were primarily focused on elite sports physiology and performance, but more recently, oCOR has also been used to answer clinical questions (Otto et al., 2017a,b). The high reliability is confirmed in this study with a TE of 1.0% for the standard oCOR method.

When CO is administered for tHb-mass determination in an open spirometry system as we did in this study for the first time, an exact determination of the exhaled CO is mandatory. We determined the exhaled CO volume twice, that is, first by continuously monitoring the volume and CO concentration of the exhaled air, and second by collecting the whole amount of expired air in a Douglas bag and measuring the exhaled CO volume after the test.

To check whether the breathing procedure after the test exerts any unexpected influence on CO exhalation, we compared a 2-min inhalation period with subsequent collection of exhaled air

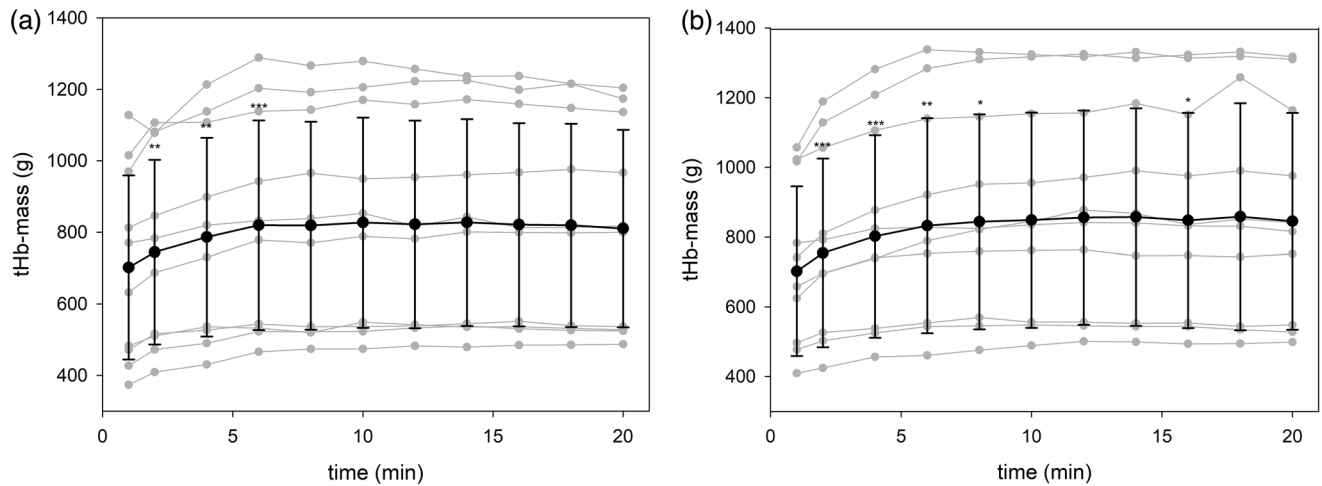

FIGURE 4 Time course of the calculated tHb-mass after CO breathing and subsequent breath holding for 15 s (a; Proc_{new}15s) and for 30 s (b; Proc_{new}30s). Presented are mean values and individual data of the tHb-mass calculated for different time points of blood sampling. Significant differences from previous values: * $P \leq 0.05$, ** $P \leq 0.01$, *** $P \leq 0.001$

TABLE 2 tHb-mass calculated from the three CO application methods

	oCOR($n = 11$)	Proc _{new} 15s($n = 11$)	Proc _{new} 30s($n = 11$)	oCOR($n = 6$)	oCOR _{+20min} ($n = 6$)
tHb-mass _{min7} (g)	843 ± 293	819 ± 285	838 ± 301	705 ± 209	665 ± 194
tHb-mass _{plateau} (g)		821 ± 288*	849 ± 311		686 ± 200
tHb-mass _{DouglasBag} (g)		830 ± 276	846 ± 309		711 ± 196

oCOR: established CO-rebreathing method; Proc_{new}15s: single CO bolus inhalation with 15 s breath holding; Proc_{new}30s: single CO bolus inhalation with 30 s breath holding; oCOR_{+20min}: 2 min CO rebreathing followed by an 18 min analysis of exhaled air; tHb-mass_{min7}: tHb-mass calculated with [COHb] determined 7 min after inhalation, tHb-mass_{plateau}: Hb-mass calculated with [COHb] determined between min 6 and min 20, tHb-mass_{DouglasBag}: tHb-mass calculated with [COHb] determined at min 20 and using the CO volume exhaled into the Douglas bag. Significant difference from oCOR: * $P < 0.05$.

(oCOR_{+20min}) with the established method (oCOR). As we did not find any difference in the resulting tHb-mass, we conclude that the exhalation protocol does not affect the precision of the new procedures.

When breath was held for 15 s, the initial CO exhalation after 1 min was twice as high as that in Proc_{new}30s, indicating that ~10% (Proc_{new}30s ~4%) of the inhaled CO did not diffuse into the blood. After 7 min, that is, when the CO mixing in the blood was completed and therefore used in the established oCOR for blood sampling after the test, the loss of CO was ~13% in Proc_{new}15s and only ~8% in Proc_{new}30s. Although this loss in CO clearly exceeded the CO volume exhaled after oCOR (~4%), these data demonstrate the rapid diffusion of CO from the lungs into the blood, which is also a precondition for the determination of the lung diffusion capacity by means of a deep inhalation of a 0.3% CO-containing gas followed by a 10-s breath hold (Modi & Cascella, 2020). We therefore suggest that tHb-mass might be easily and exactly calculated after a single breath when considering sufficient mixing time of the inhaled CO bolus.

These considerations are supported by the calculated tHb-mass over time. In the new procedures, tHb-mass reached a plateau in min 6 or in min 8 indicating complete mixing (Bruce & Bruce, 2003), that is, that any time point beyond can be used for tHb-mass and blood

volume determination (Wachsmuth et al., 2019). In this study, we used the plateau value between min 6 and 20 and compared its mean with the time point usually used in the oCOR (min 7) and with the results obtained in min 20 from the exhaled air collected in the Douglas bag. As shown in Table 2, there is no obvious difference between tHb-mass obtained from the oCOR and that obtained from the new procedures at the time points mentioned above. In the Bland–Altman plot, a small but systematic underestimation by approximately 25 g compared with the reference method becomes obvious in Proc_{new}15s. As such a deviation does not occur between Proc_{new}30s and oCOR, we suggest that the smaller CO volume taken up from the blood during Proc_{new}15s may be the cause. Additionally, the very low limits of agreement in the comparison of both new methods with oCOR indicate that Proc_{new}15s already presents a promising tool for tHb-mass and blood volume determination, and Proc_{new}30s seems to be as exact as the established oCOR.

In future studies, the administration of higher CO volumes than those used for the oCOR may be taken into consideration to compensate for the lower CO uptake during the single-breath application. On the one hand, this procedure increases the [COHb], reducing the measurement error of the CO oximeter (Alexander et al., 2011) but also increases the volume of exhaled CO and thereby

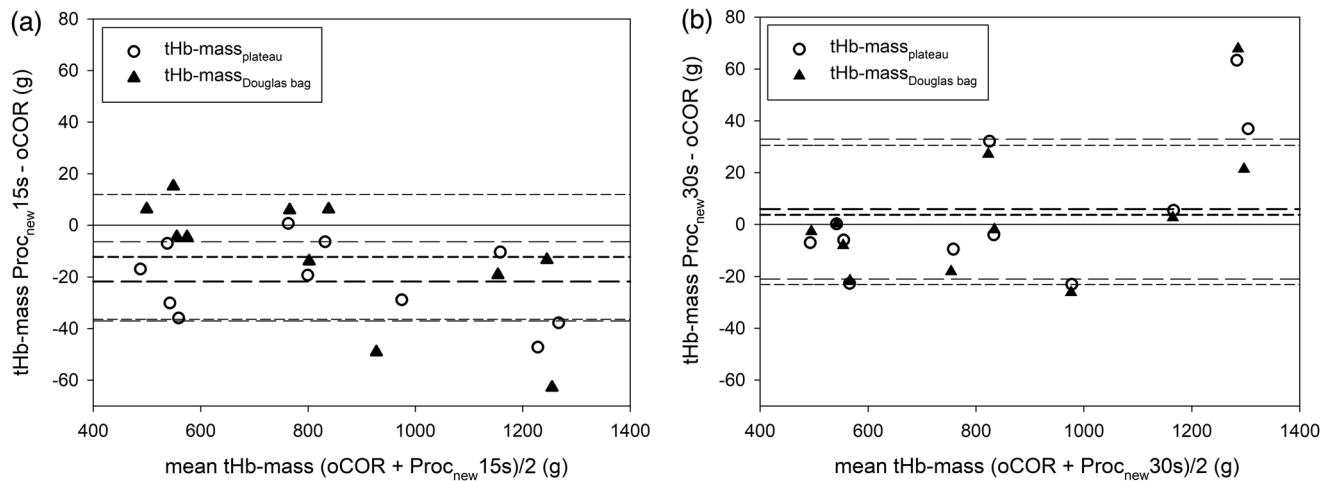

FIGURE 5 Bland–Altman plots for the comparison of tHb-mass values achieved from the new procedures (a, Proc_{new}15s; b, Proc_{new}30s) with the established CO-rebreathing method (cCOR). Long dashed lines represent the mean and SD of tHb-mass_{plateau} (Hb-mass calculated with [COHb] 6–20 min after inhalation); short dashed lines represent the mean and SD of tHb-mass_{Douglas Bag} (tHb-mass calculated with [COHb] 20 min after inhalation and the CO volume collected in the Douglas bag)

introduces another source of inaccuracy. In the literature, there has also been extensive debate about the merits of having a higher [Δ COHb%] versus the increased toxicity risk (Alexander et al., 2011; Garvican et al., 2010; Turner et al., 2014). [COHb] of up to 10% has been described without remarkable side effects in healthy subjects (Schmidt et al., 2020), but to our knowledge, it has never been studied in seriously ill patients. Because CO is endogenously produced and is actually considered for the treatment of various diseases (Motterlini & Otterbein, 2010), we are convinced that the increase in COHb by 4–5%, as achieved in our study, represents a reliable compromise balancing sources of error with minimal patient risk.

4.1 | Practical application

We hypothesize that this method might be used to diagnose and provide more information on the origin of anaemia in intensive care (Magee & Zbrozek, 2013) and the amount of blood loss during surgery (Shoemaker et al., 1996), as well as for distinguishing between dilutional anaemia and genuine anaemia in patients with heart failure (Miller & Mullan, 2015) and liver failure (Plumb et al., 2020). Here, it is of critical importance that the modified method has sufficient accuracy to reveal clinically relevant changes in tHb-mass and their contribution to changes in [Hb]. Although the reliability of the modified method was not explicitly determined in this feasibility study, the methodological error (typical error, TE; Hopkins, 2000) compared to the established method is 3.2% (Proc_{new}30s) or 3.5% (Proc_{new}15s). This is higher than the TE of the established CO rebreathing methods (TE 2.2%) but close to the TE of the gold standard methods using radioactive markers (^{51}Cr , 2.8%; Gore et al., 2005). Since even mild real anaemic states ([Hb] 11.2 g/dl) are associated with a reduction of at least ~15% tHb-mass (Wachsmuth et al., 2015), the accuracy of the method should be sufficient to distinguish anaemia due to reduced

tHb-mass from that due to dilution. This contention is supported by Otto et al. (2017a) who describe two patients with liver disease who had identical tHb-mass (9.2 g/kg body mass), but with a normal [Hb] (16.1 g/dl) in one and dilutional anaemia ([Hb] 10.7 g/dl) in the other. They also describe two cases of heart failure in which the presence of a severe reduction in tHb-mass (5.2 g/kg) was reflected in a low [Hb] in one (6.9 g/dl), but masked by a contracted PV in another ([Hb] 10.7 g/dl) (Allsop et al., 1998; Otto et al. (2017a)). In addition to the frequently occurring dilution anaemia, decompensated heart failure can also be associated with proportional increases in both tHb-mass and PV (Miller, 2016). In all these cases, the determination of the tHb-mass, also when using the modified method, enables a much more precise diagnosis.

The modification described here may permit the CO method to be used in ventilated patients. CO is applied to the inhalation path, and breathing is interrupted in the inhalation position for 15 or 30 s. The CO volume not absorbed by the patient can be determined either by collecting the entire expiratory air for a period of approximately 20 min or by continuous monitoring of the volume of the expired air and its CO concentration. These measurements are carried out until the CO is completely mixed in the blood and a blood sample for the determination of COHb is drawn.

The application of our approach to ventilated patients would offer possible clinical advantages. In most patients treated in an intensive care unit, the [Hb] drops significantly within a few days and transfusions are recommended when [Hb] reaches a threshold of 70 g/l (Watson & Kendrick, 2014) without excluding dilution. Indeed, there is no routine way in which to assess intravascular volume, with central venous pressure being a very poor guide indeed (De Backer & Vincent, 2018). In addition, blood and fluid loss during surgery are imprecisely measured and this, together with altered cardiovascular tone, and the variable administration of packed red blood cells and crystalloid/colloid solutions, makes determination of

intravascular volume (and of true Hb deficit) difficult. Our method may find application in all such situations. Nonetheless, the applicability and validity of this 'single breath method' remains to be validated in clinical circumstances.

In such clinical studies CO mixing time must be considered. It is prolonged in patients with polycythaemia (Wachsmuth et al., 2019) and heart failure (Ahlgrim et al., 2018), and perhaps also in other patient groups. This should, however, not be a major problem as the exhaled CO is collected for 20 min and a significant increase in mixing time can be tolerated if the individual COHb plateau is determined for each patient after inhalation of the CO. The use of the new method in patients with pulmonary diffusion disorders could be more problematic if sufficient CO cannot diffuse from the alveoli into the blood within 30 s. Higher CO doses may have to be used in such circumstances, but this can have an adverse effect on the accuracy of the test.

In healthy subjects, there is no risk of interrupting breathing for 30 s, and the risk can be classified as very low also in ventilated patients. Since the oxygen consumption during the 30-s breath interruption is only approximately 150 ml, the arterial O₂ saturation does not change during this period (Parkes et al., 2016); but in any case, it must be checked during and after the test. In severely anaemic patients, the test might be used with great caution after extensive validation.

5 | CONCLUSION

Using the single-breath method, tHb-mass and blood volume can be determined with approximately the same accuracy as that with established CO-rebreathing methods. We recommend that this method be developed further for use in ventilated patients, that is, patients in intensive care, patients undergoing major surgery, and patients with heart and liver failure.

ACKNOWLEDGEMENTS

The authors would like to thank all the volunteers for their engagement and participation in the study. In addition, we would like to thank Daria Schulz and Alina Wolf for their excellent technical assistance.

Open access funding enabled and organized by Projekt DEAL.

COMPETING INTERESTS

W.F.J.S. is a managing partner of the company 'Blood tec GmbH', but he is unaware of any direct or indirect conflict of interest with the contents of this paper. The remaining authors declare that the research was conducted in the absence of any commercial or financial relationships that could be construed as a potential conflict of interest.

AUTHOR CONTRIBUTIONS

L.M.K., J.O.M.P., H.E.M., N.B.W. and W.F.J.S. were involved in the conception and design of the study, the acquisition of data, the analysis and interpretation of the data, and the drafting of the manuscript. S.H., J.S., S.B.K., J.M.O. and M.P.W.G. were involved in the acquisition of data, analysis and interpretation of data for the work, as well as in the critical revision of the manuscript. All authors approved the final version of the manuscript and agreed to be accountable for all aspects of the work in ensuring that questions related to the accuracy or integrity of any part

of the work are appropriately investigated and resolved. All persons designated as authors qualify for authorship, and all those who qualify for authorship are listed.

DATA AVAILABILITY STATEMENT

The data that support the findings of this study are available from the corresponding author upon reasonable request.

ORCID

Lisa-Marie Krehl  <https://orcid.org/0000-0002-3327-138X>

James O. M. Plumb  <https://orcid.org/0000-0002-5642-8976>

Nadine B. Wachsmuth  <https://orcid.org/0000-0002-6321-3594>

Michael P. W. Grocott  <https://orcid.org/0000-0002-9484-7581>

Hugh E. Montgomery  <https://orcid.org/0000-0001-8797-5019>

Walter F. J. Schmidt  <https://orcid.org/0000-0002-9766-5564>

REFERENCES

- Ahlgrim, C., Birkner, P., Seiler, F., Grundmann, S., Baumstark, M. W., Bode, C., & Pottgiesser, T. (2018). Applying the optimized CO rebreathing method for measuring blood volumes and hemoglobin mass in heart failure patients. *Frontiers in Physiology*, 9, 1603.
- Alexander, A. C., Garvican, L. A., Burge, C. M., Clark, S. A., Plowman, J. S., & Gore, C. J. (2011). Standardising analysis of carbon monoxide rebreathing for application in anti-doping. *Journal of Science and Medicine in Sport*, 14(2), 100–105.
- Allsop, A. J., Sutherland, R., Wood, P., & Wootton, S. A. (1998). The effect of sodium balance on sweat sodium secretion and plasma aldosterone concentration. *European Journal of Applied Physiology*, 78(6), 516–521.
- Benjamini, Y., & Hochberg, Y. (1995). Controlling the false discovery rate – a practical and powerful approach to multiple testing. *Journal of the Royal Statistical Society Series B. Statistical Methodology*, 57(1), 289–300.
- Beutler, E., & Waalen, J. (2006). The definition of anemia: What is the lower limit of normal of the blood hemoglobin concentration? *Blood*, 107(5), 1747–1750.
- Bland, J. M., & Altman, D. G. (1986). Statistical methods for assessing agreement between two methods of clinical measurement. *Lancet*, 327(8476), 307–310.
- Bruce, E. N., & Bruce, M. C. (2003). A multicompartiment model of carboxyhemoglobin and carboxymyoglobin responses to inhalation of carbon monoxide. *Journal of Applied Physiology*, 95(3), 1235–1247.
- Burge, C. M., & Skinner, S. L. (1995). Determination of hemoglobin mass and blood volume with CO: Evaluation and application of a method. *Journal of Applied Physiology*, 79(2), 623–631.
- De Backer, D., & Vincent, J. L. (2018). Should we measure the central venous pressure to guide fluid management? Ten answers to 10 questions. *Critical Care*, 22(1), 43.
- Fogh-Andersen, N., Thomsen, J. K., Foldager, N., & Siggaard-Andersen, O. (1990). pH effects on the COHb absorption spectrum: Importance for calibration of the OSM3 and measurement of circulating hemoglobin and blood volume. *Scandinavian Journal of Clinical and Laboratory Investigation*, 50(203), 247–252.
- Garvican, L. A., Burge, C. M., Cox, A. J., Clark, S. A., Martin, D. T., & Gore, C. J. (2010). Carbon monoxide uptake kinetics of arterial, venous and capillary blood during CO rebreathing. *Experimental Physiology*, 95(12), 1156–1166.
- Gore, C. J., Hopkins, W. G., & Burge, C. M. (2005). Errors of measurement for blood volume parameters: A meta-analysis. *Journal of Applied Physiology*, 99(5), 1745–1758.
- Gorelov, V. (2004). Theoretical value of Hüfner's constant. *Anaesthesia*, 59(1), 97–97.
- Hopkins, W. G. (2000). Measures of reliability in sports medicine and science. *Sports Medicine*, 30(1), 1–15.

- Iijima, T., Brandstrup, B., Rodhe, P., Andrijauskas, A., & Svensen, C. H. (2013). The maintenance and monitoring of perioperative blood volume. *Perioperative Medicine*, 2(1), 9.
- Magee, G., & Zbrozek, A. (2013). Fluid overload is associated with increases in length of stay and hospital costs: Pooled analysis of data from more than 600 US hospitals. *Clinicoeconomics and Outcomes Research*, 5, 289–296.
- Makaryus, R., Miller, T. E., & Gan, T. J. (2018). Current concepts of fluid management in enhanced recovery pathways. *British Journal of Anaesthesia*, 120(2), 376–383.
- Miller, W. L. (2016). Fluid volume overload and congestion in heart failure: Time to reconsider pathophysiology and how volume is assessed. *Circulation: Heart Failure*, 9(8), e002922.
- Miller, W. L., & Mullan, B. P. (2015). Peripheral venous hemoglobin and red blood cell mass mismatch in volume overload systolic heart failure: implications for patient management. *Journal of Cardiovascular Translational Research*, 8(7), 404–410.
- Modi, P., & Cascella, M. (2020). Diffusing Capacity of the Lungs for Carbon Monoxide (DLCO) [Updated 2020 Apr 15]. In: *StatPearls* [Internet]. Treasure Island, FL, USA: StatPearls Publishing. <https://www.ncbi.nlm.nih.gov/books/NBK556149/>
- Motterlini, R., & Otterbein, L. E. (2010). The therapeutic potential of carbon monoxide. *Nature Reviews. Drug Discovery*, 9(9), 728–743.
- Otto, J. M., Plumb, J. O. M., Clissold, E., Kumar, S. B., Wakeham, D. J., Schmidt, W., & Montgomery, H. E. (2017a). Hemoglobin concentration, total hemoglobin mass and plasma volume in patients: Implications for anemia. *Haematologica*, 102(9), 1477–1485.
- Otto, J. M., Plumb, J. O. M., Wakeham, D., Clissold, E., Loughney, L., Schmidt, W., & Richards, T. (2017b). Total haemoglobin mass, but not haemoglobin concentration, is associated with preoperative cardiopulmonary exercise testing-derived oxygen-consumption variables. *British Journal of Anaesthesia*, 118(5), 747–754.
- Parkes, M. J., Green, S., Stevens, A. M., Parveen, S., Stephens, R., & Clutton-Brock, T. H. (2016). Safely prolonging single breath-holds to >5 min in patients with cancer; feasibility and applications for radiotherapy. *British Journal of Radiology*, 89(1063), 20160194.
- Plumb, J. O., Otto, J. M., & Grocott, M. P. (2016). 'Blood doping' from Armstrong to prehabilitation: Manipulation of blood to improve performance in athletes and physiological reserve in patients. *Extreme Physiology & Medicine*, 5, 5.
- Plumb, J. O. M., Otto, J. M., Kumar, S. B., Wright, M., Schmidt, W., Grocott, M. P. W., & Montgomery, H. E. (2020). Application of the optimized carbon monoxide rebreathing method for the measurement of total haemoglobin mass in chronic liver disease. *Physiological Reports*, 8(6), e14402.
- Prommer, N., & Schmidt, W. (2007). Loss of CO from the intravascular bed and its impact on the optimised CO-rebreathing method. *European Journal of Applied Physiology*, 100(4), 383–391.
- Rassam, S. S., & Counsell, D. J. (2005). Perioperative fluid therapy. *BJA Education*, 5(5), 161–165.
- Schmidt, W., & Prommer, N. (2005). The optimised CO-rebreathing method: A new tool to determine total haemoglobin mass routinely. *European Journal of Applied Physiology*, 95(5–6), 486–495.
- Schmidt, W. F. J., Hoffmeister, T., Haupt, S., Schwenke, D., Wachsmuth, N. B., & Byrnes, W. C. (2020). Chronic exposure to low dose carbon monoxide alters hemoglobin mass and VO₂max. *Medicine and Science in Sports and Exercise*, 52(9), 1879–1887.
- Shander, A., & Ferraris, V. A. (2017). More or less? The Goldilocks Principle as it applies to red cell transfusions. *British Journal of Anaesthesia*, 118(6), 816–819.
- Shoemaker, J. K., Green, H. J., Coates, J., Ali, M., & Grant, S. (1996). Failure of prolonged exercise training to increase red cell mass in humans. *American Journal of Physiology*, 270(1 Pt 2), H121–H126.
- Strunden, M. S., Heckel, K., Goetz, A. E., & Reuter, D. A. (2011). Perioperative fluid and volume management: Physiological basis, tools and strategies. *Annals of Intensive Care*, 1(1), 2.
- Turner, G., Pringle, J. S., Ingham, S. A., Fudge, B. W., Richardson, A. J., & Maxwell, N. S. (2014). The influence of carbon monoxide bolus on the measurement of total haemoglobin mass using the optimized CO-rebreathing method. *Physiological Measurement*, 35(2), N11–N19.
- Wachsmuth, N., Soria, R., Jimenez, J., & Schmidt, W. (2019). Modification of the CO-rebreathing method to determine haemoglobin mass and blood volume in patients suffering from chronic mountain sickness. *Experimental Physiology*, 104(12), 1819–1828.
- Wachsmuth, N. B., Aigner, T., Völzke, C., Zapf, J., & Schmidt, W. F. (2015). Monitoring recovery from iron deficiency using total hemoglobin mass. *Medicine & Science in Sports & Exercise*, 47(2), 419–427.
- Watson, S., & Kendrick, K. (2014). Management of anaemia and blood transfusion in critical care - implementing national guidelines in ICU. *BMJ Quality Improvement Reports*, 3(1), u202106.w1109.

How to cite this article: Krehl L-M, Plumb JO, Wachsmuth NB, et al. A carbon monoxide 'single breath' method to measure total haemoglobin mass: a feasibility study. *Experimental Physiology*. 2021;106: 567–575.
<https://doi.org/10.1113/EP089076>